

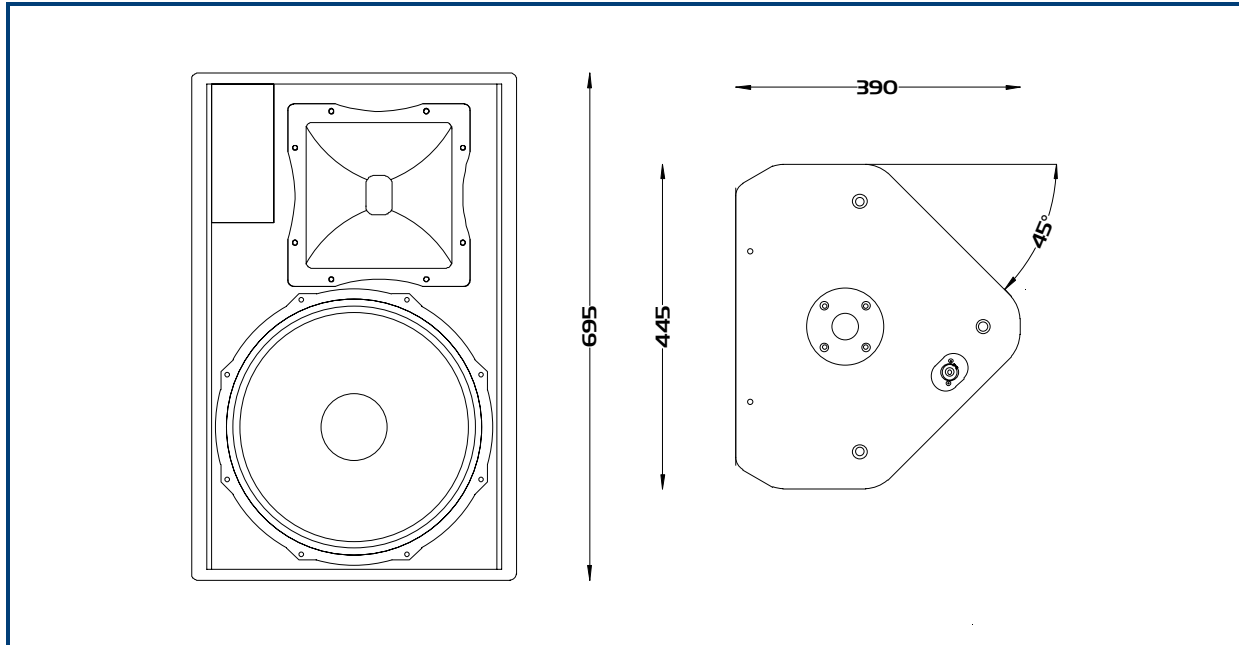

The ML15 is a, high power, multipurpose, fullrange loudspeaker enclosure. The cabinet combines a 15” mid/bass cone with a 1.4” neodymium compression driver on a 90 x 40 horn flare. The horn flare rotates to aid use in both landscape and portrait applications. The cabinet can be used Fullrange or combined with the SB1 bass enclosure to form an integrated system. The ML15 contains an internal passive crossover network, but for optimum sonic performance should be used with the DP2140 system controller. The Logic System DP2140 controller contains presets for using the cabinet freestanding or as a system. The multipurpose nature of the cabinet makes it suitable for a variety of applications including, FOH, monitoring, stage fills and delays. Target markets for the product include, church, live sound, theatre and A/V.



<b>Frequency Response:</b>	• 50Hz – 18kHz
<b>Components:</b>	• Bass/mid: 15” cone driver • HF: 1.4” exit neodymium compression driver
<b>Power handling:</b>	• 500w
<b>Sensitivity (1):</b>	• 99dB
<b>Directivity:</b>	• 90° x 40° above 1.5 kHz (60° x 40° Optional.)
<b>Impedance:</b>	• 8 Ohm
<b>Construction:</b>	• 15mm Birch plywood
<b>Finish:</b>	• Water based textured black paint
<b>Connections:</b>	• 4 x Neutrik NL4 connectors • 1+/1- Input 2+/2- linked.
<b>Dimensions:</b>	• 445mm (W) x 695mm (H) x 390mm (D)
<b>Packaged Dimensions:</b>	• 555mm (W) x 815mm (H) x 500mm (D)
<b>Weight:</b>	• 31.1Kg

Cabinet	Handles	Tophat	M20 plate	Castors	Bracket Pt.	Inserts/Fly Points
ML 15	2 off	Yes	No	No	Top/Side	6 off

**Note:** (1) Sensitivity measured at 1 metre with 2.83V, using band limited pink noise.