

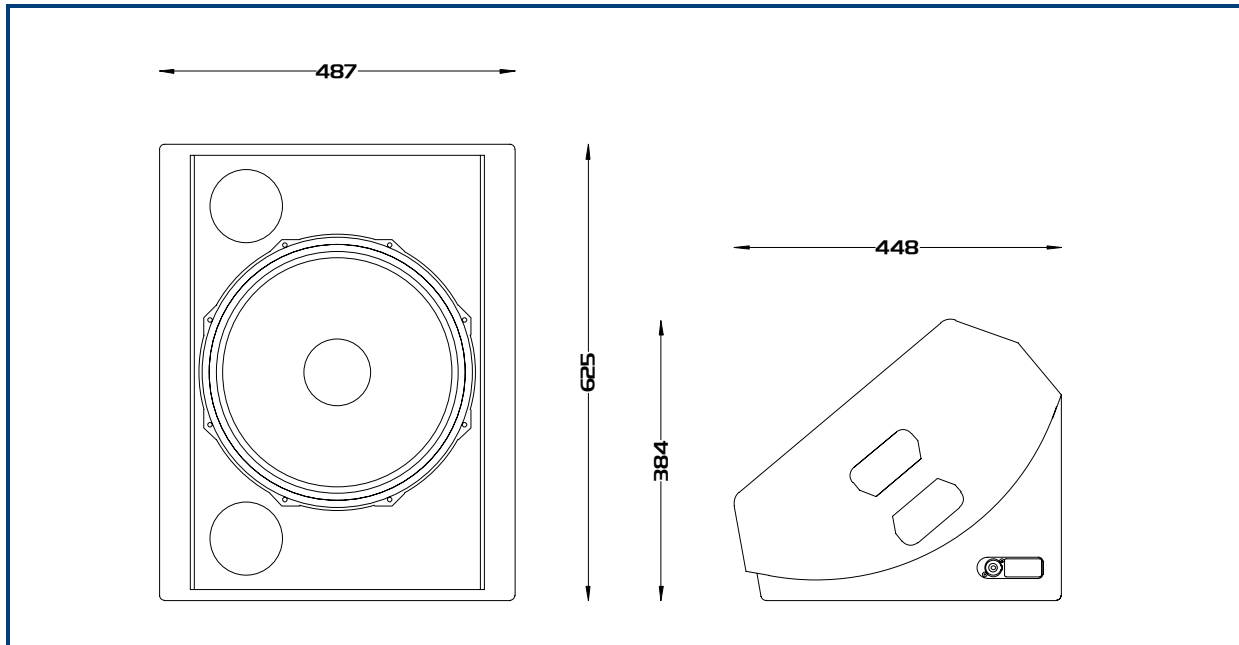

The LM Series is a range of state of the art live sound stage monitors. The LM20 cabinet combines a 15" Neodymium Mid/Bass cone with a coaxially mounted 1.4" neodymium compression driver. The cabinet is switchable between, active and passive modes, with an active only version available. The coaxial layout has many acoustic advantages and also means that with a centrally mounted HF driver matched pairs are not required. To aid functionality the cabinet has a handle mounted tophat mount which enables the cabinet to be used for small front of house applications. The monitor also benefits from being low profile to improve those all important site lines. Another useful feature is link through speakons on the cabinet ends, ensuring neat cabling when used as pairs.



Frequency Response:	• 55Hz – 18kHz
Components:	• Bass/mid: 15" neodymium cone driver • HF: 1.4" exit neodymium coaxial compression driver
Power handling:	• 600w
Sensitivity (1):	• 99dB
Directivity:	• 60° conical above 1kHz
Impedance:	• 8 Ohms nominal
Construction:	• 15mm Birch plywood
Finish:	• Water based textured black paint
Connections:	• 2 x Neutrik NL4 connectors (one each end) • 1+/1- Input 2+/2- linked for active mode.
Dimensions:	• 487mm (W) x 625mm (H) x 450mm (D)
Packaged Dimensions:	• 560mm (W) x 745mm (H) x 490mm (D)
Weight:	• 27 Kg

Cabinet	Handles	Tophat	M20 plate	Castors	Bracket Pt.	Inserts/Fly Points
LM15	2 off	Yes	No	No	No	No

Note: (1) Sensitivity measured at 1 metre with 2.83V, using band limited pink noise

E: sales@logic-system.co.uk T: +44(0)1427 611791 w: www.logic-system.co.uk