

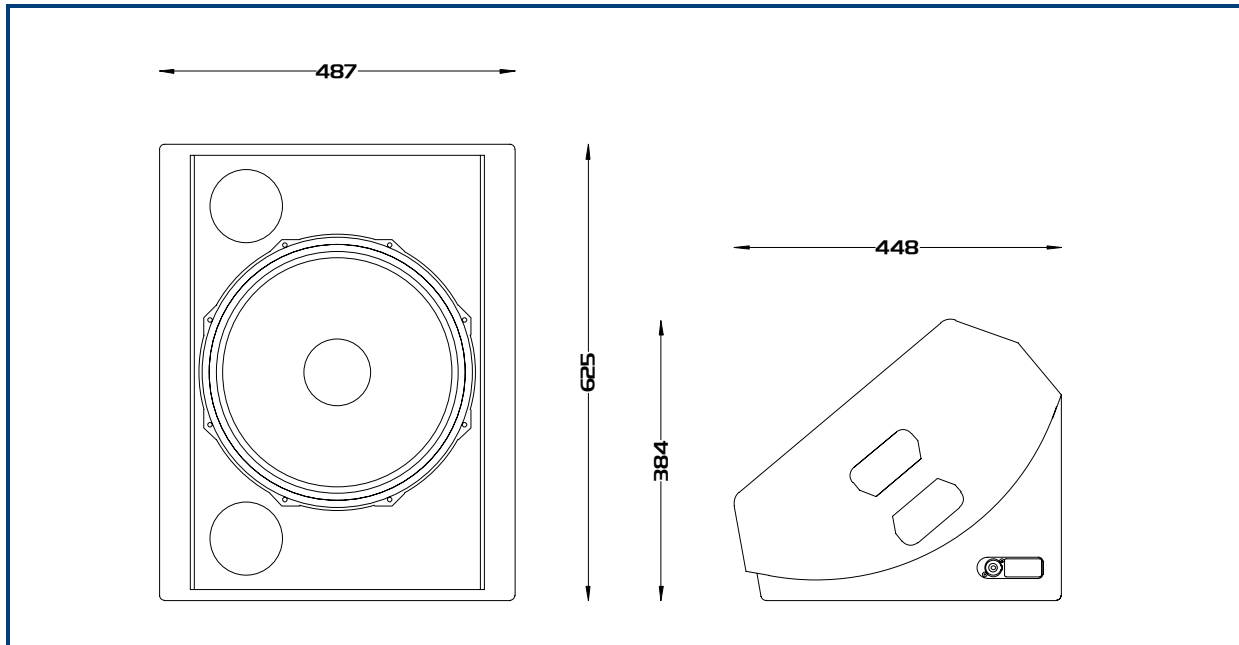

The LM Series is a range of state of the art live sound stage monitors. The LM15 cabinet combines a 15” Neodymium Mid/Bass cone with a coaxially mounted 1.4” compression driver, which is passively crossed over. The coaxial layout has many acoustic advantages and also means that with a centrally mounted HF driver matched pairs are not required. To aid functionality the cabinet also benefits from a tophat mount which enables the cabinet to be used for small front of house applications. The monitor also benefits from being low profile to improve those all important site lines. Another useful feature is link through speakons on the cabinet ends, ensuring neat cabling when used as pairs.



<b>Frequency Response:</b>	<ul style="list-style-type: none"> <li>• 55Hz – 18kHz</li> </ul>
<b>Components:</b>	<ul style="list-style-type: none"> <li>• Bass/mid: 15” neodymium cone driver</li> <li>• HF: 1.4” exit compression driver, coaxially mounted</li> </ul>
<b>Power handling:</b>	<ul style="list-style-type: none"> <li>• 600w</li> </ul>
<b>Sensitivity (1):</b>	<ul style="list-style-type: none"> <li>• 99dB</li> </ul>
<b>Directivity:</b>	<ul style="list-style-type: none"> <li>• 60° conical above 1kHz</li> </ul>
<b>Impedance:</b>	<ul style="list-style-type: none"> <li>• 8 Ohms nominal</li> </ul>
<b>Construction:</b>	<ul style="list-style-type: none"> <li>• 15mm Birch plywood</li> </ul>
<b>Finish:</b>	<ul style="list-style-type: none"> <li>• Water based textured black paint</li> </ul>
<b>Connections:</b>	<ul style="list-style-type: none"> <li>• 2 x Neutrik NL4 connectors (one each end)</li> <li>• 1+/1- Input 2+/2- no connection</li> </ul>
<b>Dimensions:</b>	<ul style="list-style-type: none"> <li>• 487mm (W) x 625mm (H) x 450mm (D)</li> </ul>
<b>Packaged Dimensions:</b>	<ul style="list-style-type: none"> <li>• 560mm (W) x 745mm (H) x 490mm (D)</li> </ul>
<b>Weight:</b>	<ul style="list-style-type: none"> <li>• 27 Kg</li> </ul>

Cabinet	Handles	Tophat	M20 plate	Castors	Bracket Pt.	Inserts/Fly Points
LM15	1 off	Yes	No	No	No	No

**Note:** (1) Sensitivity measured at 1 metre with 2.83V, using band limited pink noise

E: sales@logic-system.co.uk T: +44(0)1427 611791 w: www.logic-system.co.uk